



JOHN DEERE

OPERATOR'S MANUAL
20-bu Click-N-Go Material Collection System

LP68577
Supplier ST48291
02/15/2019
English

Introduction

Using Your Operator’s Manual

Read this entire operator’s manual, especially the safety information, before operating.

This manual is an important part of your machine. Keep all manuals in a convenient location so they can be accessed easily.

Use the safety and operating information in the attachment operator’s manual, along with the machine operator’s manual, to operate and service the attachment safely and correctly.

If your attachment manual has a section called Preparing the Machine, it means that you will have to do something to your tractor or vehicle before you can install the attachment. The Assembly and Installation sections of this manual provide information to assemble and install the attachment to your tractor or vehicle. Use the Service section to make any needed adjustments and routine service to your attachment.

If you have any questions or concerns with the assembly, installation, or operation of this attachment, see your local John Deere dealer or call the John Deere Customer Contact Center at 1-888-867-2238 for assistance.

Warranty information on this John Deere attachment can be found in the warranty that came with your John Deere tractor or vehicle.

Table of Contents

Introduction	2
Product Compatibility.....	2
Safety Labels.....	3-4
Safety	5-6
Assembly - Parts in Kit	7
Installation	8-10
Operation.....	11
Removal and Storage	12
Specifications	13
Good Quality Service.....	15
Warranty	16

Product Compatibility

The 20-bushel MCS is compatible with X700 Signature Series Tractors.

Original instructions. All information, illustrations and specifications in this manual are based on the latest information available at the time of publication.

The right is reserved to make changes at any time without notice.

Safety Labels

Safety Labels

Safety Label Location

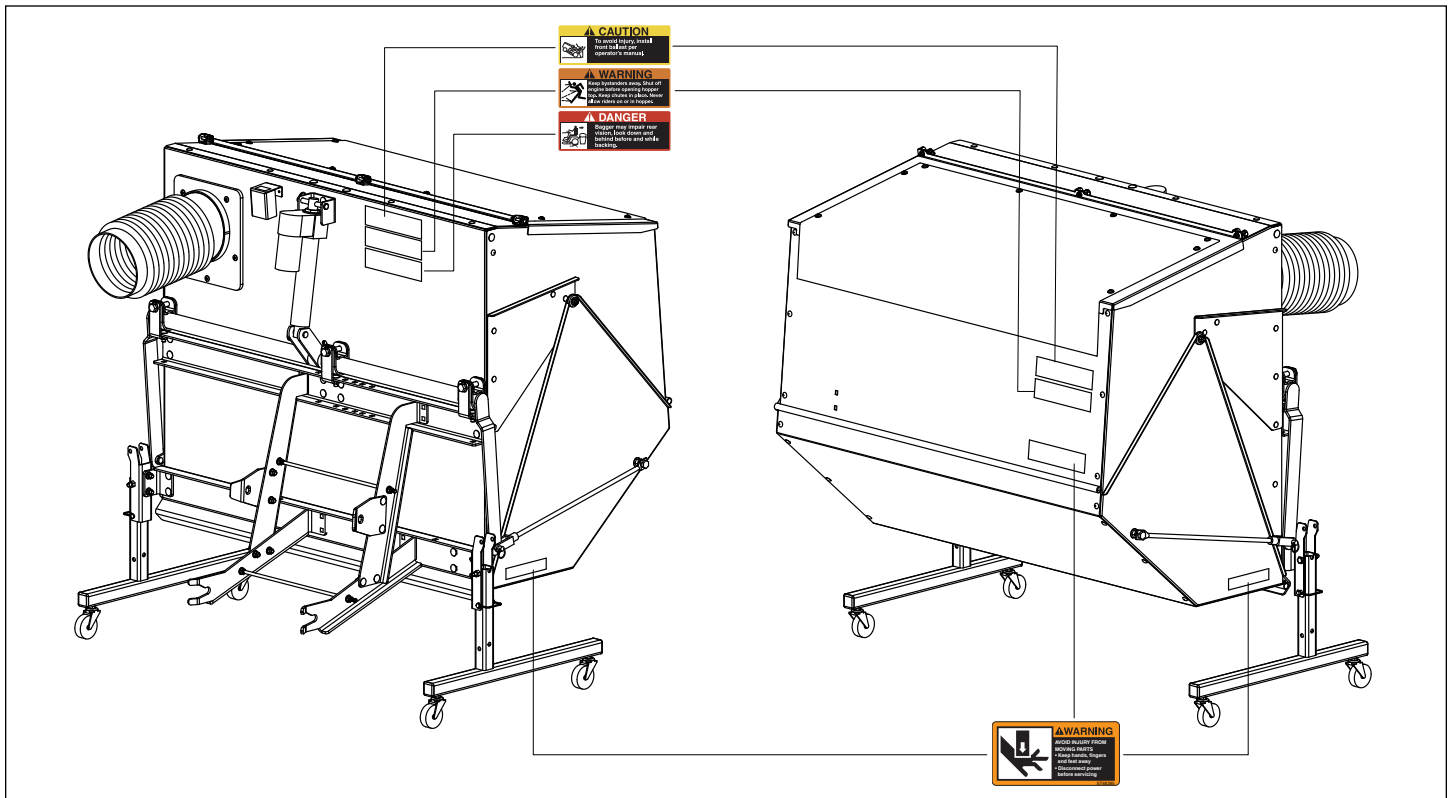

Understanding The Machine Safety Labels



The machine safety labels shown in this section are placed in important areas on your machine to draw attention to potential safety hazards.

On your machine safety labels, the words **DANGER**, **WARNING**, and **CAUTION** are used with this safety-alert symbol. **DANGER** identifies the most serious hazards.

The operator's manual also explains any potential safety hazards whenever necessary in special messages that are identified with the word, **CAUTION**, and the safety-alert symbol.

Replace missing or damaged safety labels. Use this operator's manual for correct safety label placement.

There can be more safety information contained on parts and components sourced from suppliers that is not reproduced in this operator's manual.

French or Spanish Safety Labels and Operator's Manual

Operator's manuals and safety labels with content in French or Spanish are available for this machine through authorized John Deere dealers.

Warning

Avoid Injury From Moving Parts



- Keep hands, feet and clothing away
- Disconnect power before servicing

Safety Labels

Warning



To Avoid Injury From Thrown Objects

- Keep bystanders away
- Shut off engine before opening hopper top
- Keep chutes in place
- Never allow riders on hopper top or on frame
- Disconnect power before servicing

Caution



To Avoid Injury

- Install front ballast per operator's manual

Danger



Bagger may impair rear vision

- Look down and behind before and while backing

Safety

Read Safety in Machine Operator's Manual

Read the general safety operating precautions in your machine installation instruction manual for additional safety information.

- The MCS is limited to carrying only grass or leaves.
- Be aware when maneuvering your machine because the MCS increases vehicle length.
- DO NOT allow anyone to ride in the MCS.
- Be aware of the potential pinch point when closing the tailgate.

Operating Safely

- Read the machine and attachment operator's manual carefully. Be thoroughly familiar with the controls and the proper use of the equipment. Know how to stop the machine and disengage the controls quickly.
- This attachment is intended for use in lawn and property maintenance applications. Do not use for use other than intended by the manufacturer.
- Do not modify machine or safety devices. Unauthorized modifications to the machine or attachment may impair its function and safety.
- Do not let children or an untrained person operate machine.
- Make any necessary adjustments before you operate. Never attempt to make any adjustments while the engine is running, unless if recommended in adjustment procedure.
- Look behind machine before you back up. Back up carefully.
- Do not let anyone, especially children, ride on machine or attachment. Riders are subject to injury such as being struck by foreign objects and being thrown off. Riders may also obstruct the operator's view, resulting in the machine being operated in an unsafe manner.
- Disengage any power to the attachment when the machine is transported or not in use.

Parking Safety

1. Stop machine on a level surface.
2. Lock the park brake
3. Stop the engine
4. Remove the key
5. Wait for engine and all moving parts to stop before you leave the operator's seat

Practice Safe Maintenance

- Only qualified, trained adults should service this machine.
- Understand service procedure before doing work. Keep area clean and dry.
- Do not operate the engine in a confined space where dangerous carbon monoxide fumes can collect.
- Never lubricate, service or adjust the machine or attachment while it is moving. Keep safety devices in place and in working condition. Keep hardware tight.
- Keep hands, feet, clothing, jewelry, and long hair away from any moving parts, to prevent them from getting caught.
- Lower any attachment completely to the ground or to an existing attachment mechanical stop before servicing the attachment. Disengage all power and stop the engine. Lock park brake and remove the key. Let machine cool.
- Disconnect battery or remove spark plug wire (for gasoline engines) before making any repairs.
- Before servicing machine or attachment, carefully release pressure from any components with stored energy, such as hydraulic components and springs.
- Release hydraulic pressure by lowering attachment or cutting units to the ground or to a mechanical stop and move hydraulic control levers.

Safety

- Securely support any machine or attachment elements that must be raised for service work. Use jack stands or lock service latches to support components when needed.
- Never run engine unless park brake is locked.
- Keep all parts in good condition and properly installed. Fix damage immediately. Replace worn or broken parts. Replace all worn or damaged safety and instruction decals.
- Check all hardware at frequent intervals to be sure the equipment is in safe working condition.
- Do not modify machine or safety devices. Unauthorized modifications to the machine or attachment may impair its function and safety

Wear Appropriate Clothing



- Always wear eye protection when operating the machine.
- Wear close fitting clothing and safety equipment appropriate for the job.
- While operating this machine, always wear substantial footwear and long trousers. Do not operate the equipment when barefoot or wearing open sandals.
- Wear a suitable protective device such as earplugs. Loud noise can cause impairment or loss of hearing.

Assembly

Parts In Kit

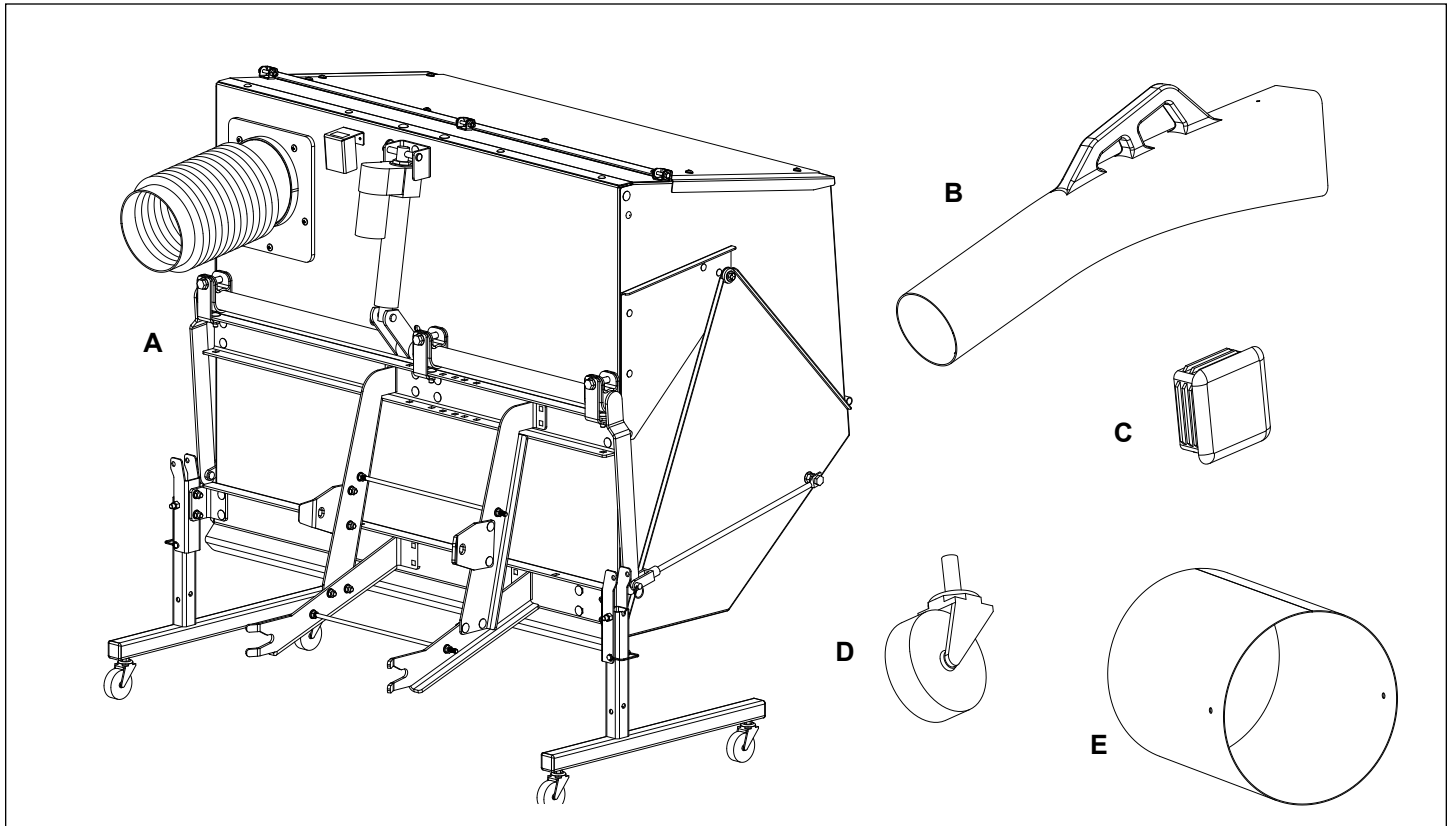

Main Attachment and Chute Assembly

Description	Letter	Qty
MCS Assembly	A	1
Chute Assembly (shipped inside bin)	B	1
Plastic Tube Cap	C	4

Wheel Kit

Description	Letter	Qty
Caster Wheels	D	4
3/8 Flange Nut	Not Shown	8

Wiring Kit

Description	Letter	Qty
Vehicle Harness	Not Shown	1
Wire Tires	Not Shown	10

Chute Extension Assembly

The ST70008 Update Kit for the 20-bu Click-N-Go Material Collection System (LP68577) provides additional length to the chute and is required when using a 60" mower deck, Power Flow blower and the 20-bu Click-N-Go Material Collection System. The kit ensures that the chute does not become disengaged during low deck height operation. The kit still allows for ease of chute removal.

Chute Extension

Description	Letter	Qty
Extension Tube	E	1
#10-24 Nylock Nut	Not Shown	2
#10 S.S. Washer	Not Shown	2
#10-24 X 1/2" S.S. Phillips Head Screw	Not Shown	2

Tools Required

3/16" Drill Bit
3/8" Wrench
Phillips Head Screw Driver

Installation

Front Ballast

Requires four 42-lb (19-kg) suitcase weights (Part number R66949); not included.

Wiring Instructions

1. From the inside of the rear right side of vehicle frame, insert pictured wire ends of vehicle harness through slot (A).

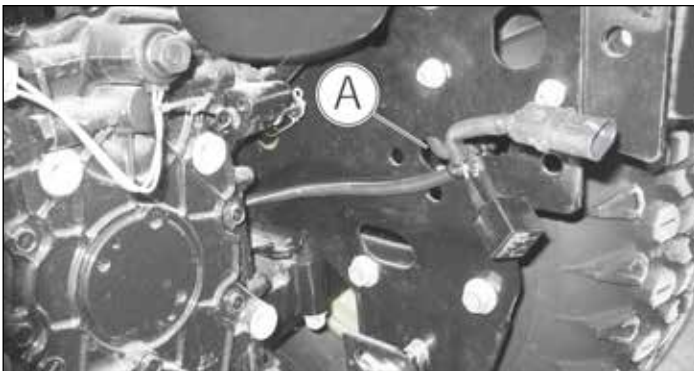

2. Reach under rear fender and unplug the underside of the 12v outlet. Plug the wire ends in line between the underside of the outlet (B) and the removed plug (C).

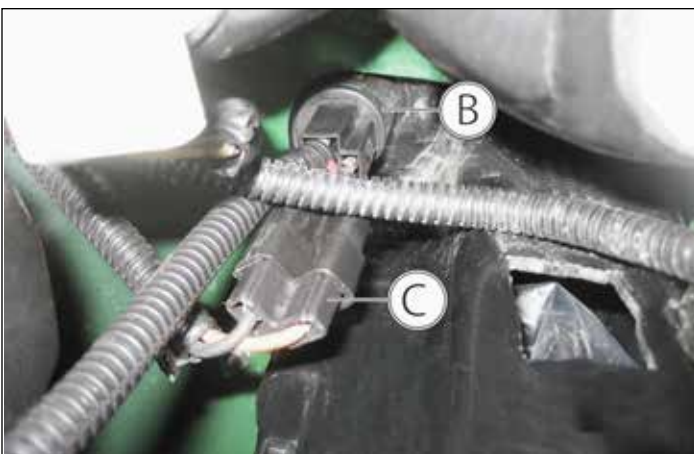

3. Wire tie (D) to frame keeping the wire away from the tire. Also wire tie relay in place where this wire comes through frame.

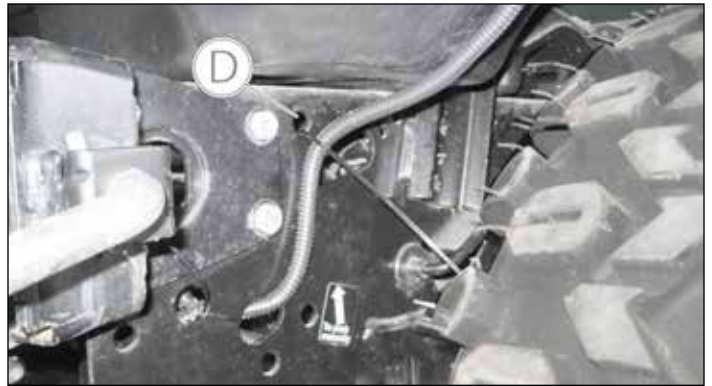

4. Route the long end of wire forward above the lip on bottom of frame (E) to the battery.

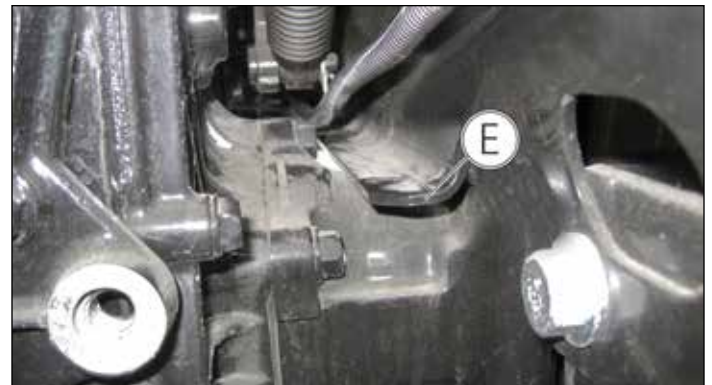

5. Wire tie to the frame at the cross brace (F).



6. Connect ring terminals to battery, red to positive (G), black to negative (H).



Installation

Mounting MCS

1. For initial install, it is recommended that two people lift MCS onto the Click-N-Go brackets. MCS weighs 225 lb (102 kg).
2. Plug wire from switch into free wire end at rear of tractor.
3. Connect chute from Power Flow Blower Assembly to MCS.

Installation

1. With tractor parking brake engaged, roll the MCS into position to align with Click-N-Go.
2. Push on the rear of MCS until it clicks to lock into place.
3. Fold legs up and lock into place with wire lock pins.
4. Install chute.
5. Plug in actuator.

Caster Wheel Assembly

1. With MCS mounted on tractor, remove wire lock pin (A), rotate the foot up and replace pin in hole (B).

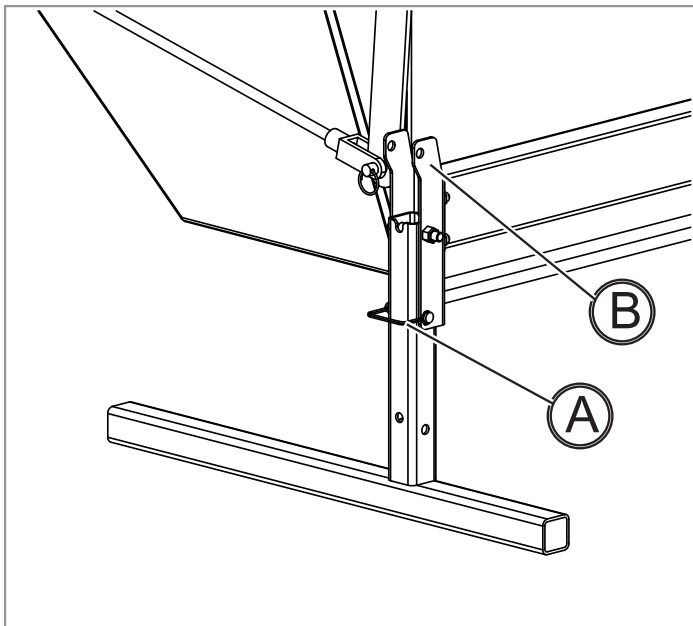

2. Install the caster wheels (C) on the feet using enclosed flange nuts (E) on inside and outside of tube.
3. Insert Plastic tube Cap(D) into ends of tube.

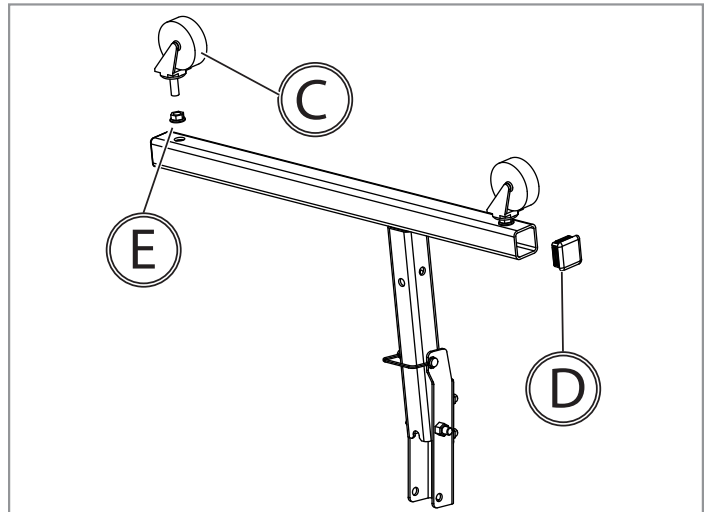

Installing Chute Extension (If required)

1. Slide the tube extension until the edge aligns with the "D" line on the chute.



2. Using a 3/16" drill bit, drill two holes in the chute. Use the pre-drilled holes in the extension tube (A) as a guide.

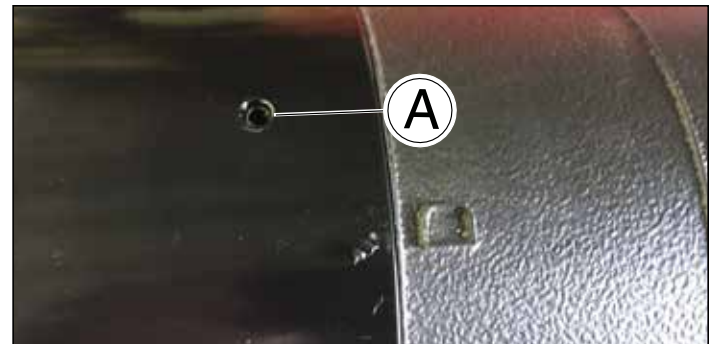

Installation

3. Install #10-24 X 1/2" S.S. Phillips Head into the hole.
4. Install #10 Washer (C) and Nut (B).

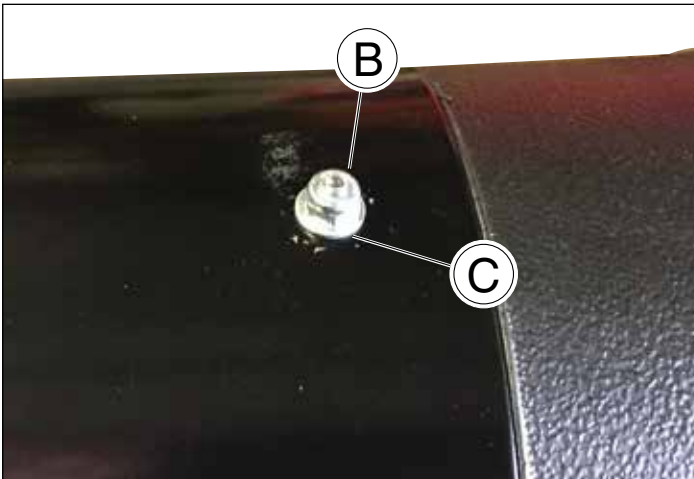

5. Tighten screw and nut using a 3/8" wrench and Phillips head screw driver.
6. For the hole on the opposing side, repeat steps 5 through 7.
7. Re-install the chute into the 20-bu Click-N-Go Material Collection System and Power Flow blower.

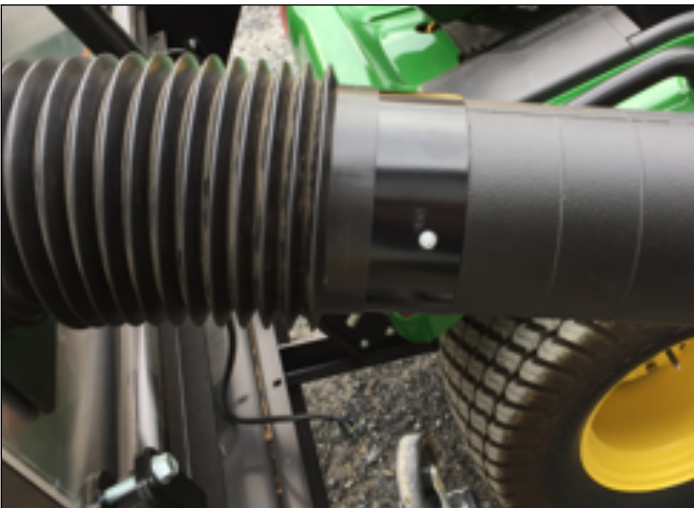

Connecting Chute

1. Insert the Upper chute (A) a minimum of 6" into the MCS chute (B).

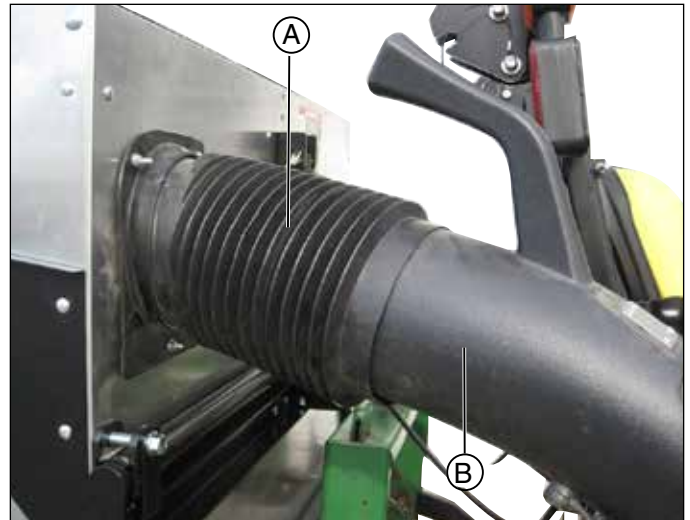

2. Connect the rectangular end of the Lower Chute (C) to the power flow (D), secure with strap (E).

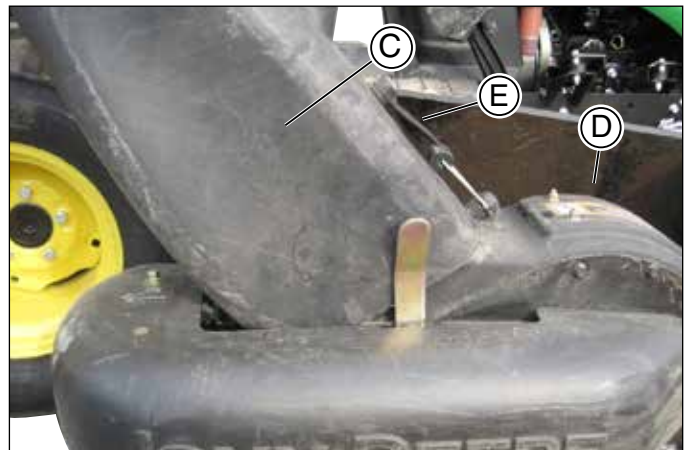

Operation

1. To empty, hold control switch in the open position until fully open. Drive forward away from pile before closing. To close, hold the control switch in the close position until fully closed.
2. Do not back up vehicle while emptying.

Note: Flip legs up before use.

DO NOT set MCS down on legs with material in hopper.

DO NOT open MCS if it is not connected to tractor.

Note: To prevent damage to the MCS, DO NOT operate with legs in down position.

Removal

Removing MCS

1. It is recommended that tractor and MCS are parked on flat ground for removal.
2. Unplug switch wire.
3. Remove chute.
4. Fold legs down and lock in place with wire lock pins.
5. Pull out the top pins on the Click-N-Go brackets.
6. Wheel MCS away.

Specifications

MCS

Hopper Volume	0.7 cu m (25 cu ft)
---------------	---------------------

Dimensions

Length	27 in (69 cm)
Width	48 in (121 cm)
Height	39 in (99 cm)

Weight

Empty	225 lb (102 kg)
-------	-----------------

Materials

Hopper	Aluminum
Hopper Gate	Steel
Lid	Perforated Aluminum with Fabric Cover
Chute	Polyethylene

This page intentionally left blank

Good Quality Service

John Deere provides a process to handle your questions or problems, should they arise, to ensure that product quality continues with quality parts and service support.

Follow the steps below to get answers to any questions you may have about your product.

Refer to your attachment and machine operator manuals.

In North America or Canada, call Superior Tech Customer Service at 1-888-867-2238 and provide product serial number (if available) and model number.

Warranty

Limited Warranty for New John Deere Licensed Products

Superior Tech's attachments are guaranteed to be free from defects in material and workmanship from the date of purchase for 1 year residential use, 6 months commercial use, provided that the purchaser properly assembles, installs, uses and maintains the products in accordance with this manual.

Purchaser's failure to adhere to such requirements will void the warranty. To the extent permitted by applicable law, all other warranties, representations, obligations and conditions, expressed or implied, including but not limited to implied warranties of merchantability, fitness for any particular purpose and non-infringement, are hereby disclaimed and excluded.

Any product which does not meet warranty shall, as purchaser's sole and exclusive remedy, be repaired or replaced by Superior Tech. This warranty is non-transferable.

- In addition, our warranty does not cover:
- Labor charges.
- Loss or consequential, incidental or special damages of any kind.

This product was manufactured by Superior Tech, Inc, a John Deere Licensee, located at 1811 Rohrerstown Road, Lancaster PA 17601. If you have any questions or concerns with the assembly, installation, or operation of this attachment, see your local John Deere dealer or call Superior Tech at 1-888-867-2238 for assistance.

