



JOHN DEERE

INSTALLATION INSTRUCTIONS

EZtrak Z400, Z600 / ZTrak Z500

Boarding Step

ST50634 09/08/2016

ENGLISH

LP66655

Product Compatibility

This kit is compatible with EZTrak Z400 and Z600 (2015 and prior) and ZTrak Z500 (2016 and later) series mowers.

Parts in Kit

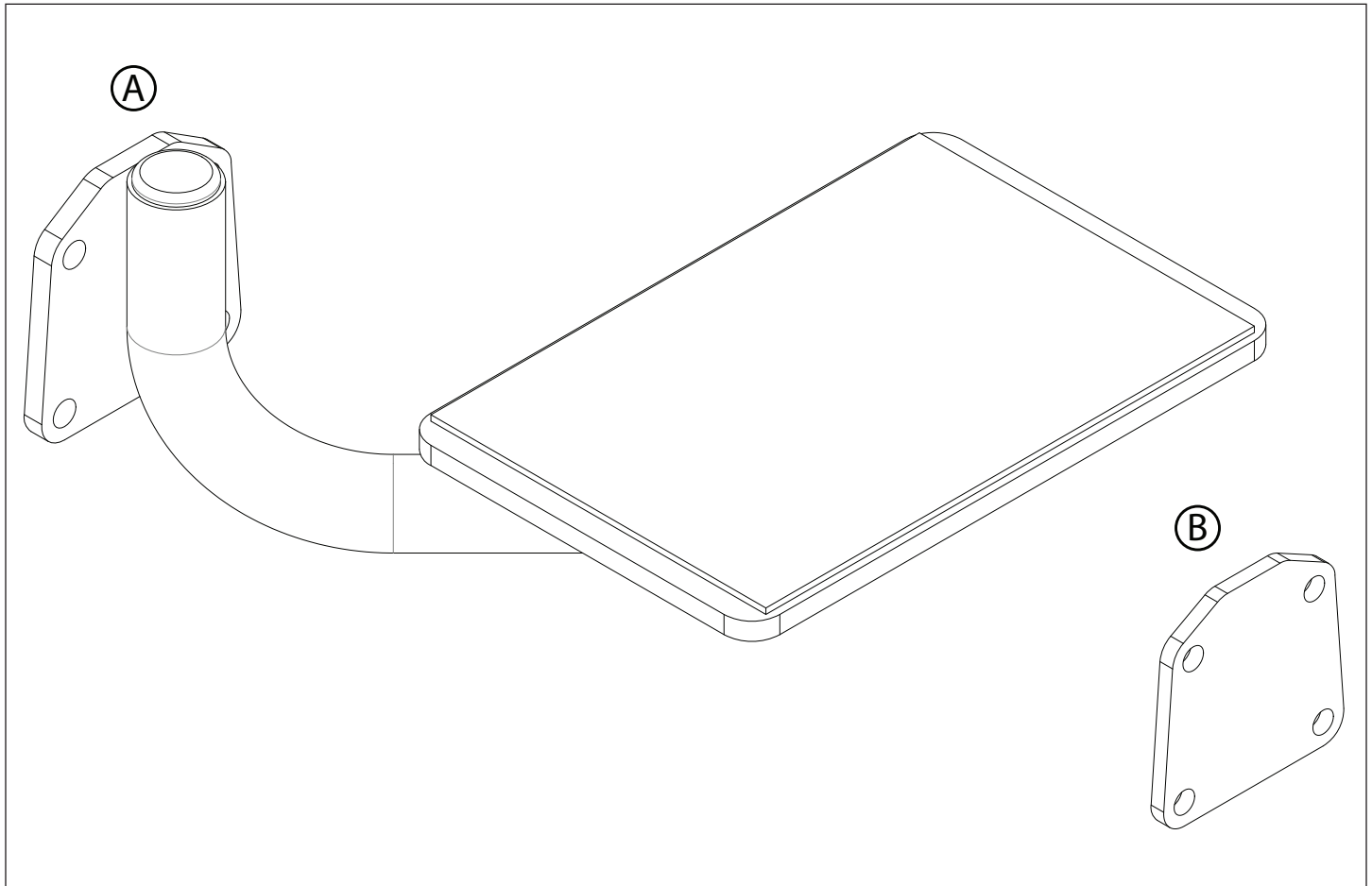

Parts Description	Qty	Hardware Bag	Qty
Platform (A)	1	3/8" x 2 3/4" Flange Bolt	4
Clamp Plate (B)	1	3/8" Flange Nut	4

NOTE: Retain these installation instructions with the machine operator's manual.

Installing

Parking Safely

1. Stop machine on a level surface
2. Disengage mower blades
3. Move motion control levers out to the Start/Shutdown position
4. Lock the park brake
5. Stop the engine
6. Remove the key
7. Wait for engine and all moving parts to stop before you leave the operator's seat
8. Disconnect the negative battery cable or remove the spark plug wire (for gasoline engines) before servicing the machine

Installing

1. Use 3/8" x 2 3/4" flange bolts and 3/8" flange nuts to attach platform (A) and clamp plate (B) to left side frame rail underneath foot rest. Hand-tighten bolts.
2. Confirm Boarding Step is level front to back and clears frame, deck, and front wheel assembly components.
3. Use wrench to hold flange nuts on the inside of the mower while tightening flange bolts on the outside.

Operation

Board the vehicle as listed in the vehicle owner's manual or from the left side by utilizing the boarding step.

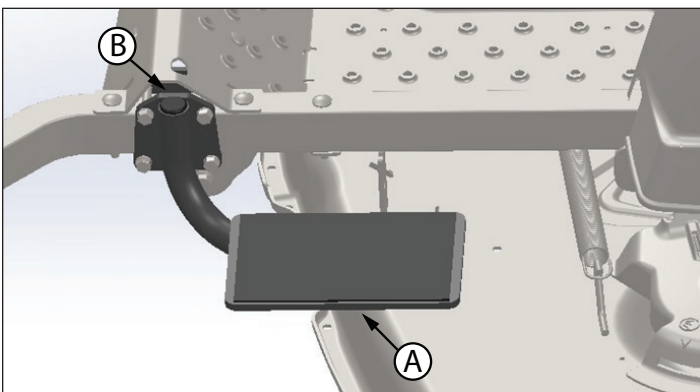

Warranty

Limited Warranty for New John Deere Licensed Products

Superior Tech's Boarding Step is guaranteed to be free from defects in material and workmanship from the date of purchase for 2 years residential use, 6 months commercial use, provided that the purchaser properly assembles, installs, uses and maintains the products in accordance with this manual.

Purchaser's failure to adhere to such requirements will void the warranty. To the extent permitted by applicable law, all other warranties, representations, obligations and conditions, expressed or implied, including but not

limited to implied warranties of merchantability, fitness for any particular purpose and non-infringement, are hereby disclaimed and excluded.

Any product which does not meet warranty shall, as purchaser's sole and exclusive remedy, be repaired or replaced by Superior Tech. This warranty is non-transferable.

In addition, our warranty does not cover:

- Labor charges
- Loss or consequential, incidental or special damages of any kind

This product was manufactured by Superior Tech, Inc, a John Deere Licensee, located at 43 Industrial Road, Ephrata, PA 17522. If you have any questions or concerns with the assembly, installation, or operation of this attachment, see your local John Deere dealer or call Superior Tech at 1-888-867-2238 for assistance.

