



JOHN DEERE

Product Services Information

INSTALLATION INSTRUCTIONS



JOHN DEERE

TX Attachment Mounting Frame and Display

Safety

Read the general safety operating precautions in your machine installation instruction manual for additional safety information.

✱ Use only with John Deere approved attachments



Using your Instruction Manual

Read the Installation Manual in entirety, especially the safety information, before operating.

If your Instruction Manual has a section called Preparing the Machine, it means that you will have to do something to your tractor or vehicle before you can install the attachment. The Assembly and Installation sections of this manual provide information to assemble and install the attachment to your tractor or vehicle. Use the Service section to make any needed adjustments and routine service to your attachment.

This product was manufactured by Superior Tech, Inc, a John Deere Licensee, located at 1811 Rohrerstown Rd, Lancaster, PA 17601. If you have any questions or concerns with the assembly, installation, or operation of this attachment, see your local John Deere dealer or call Superior Tech at 1-888-867-2238 for assistance.

Parts in Kit

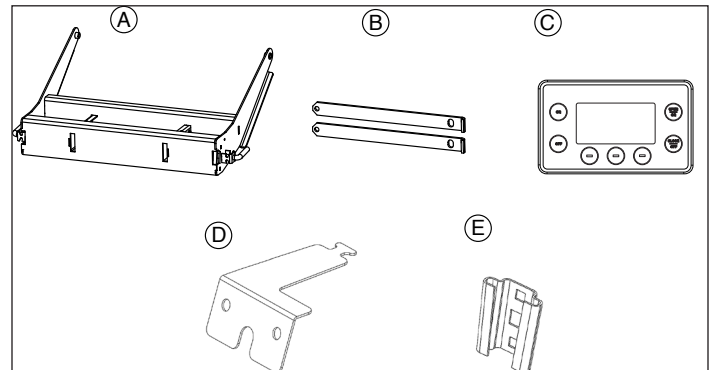

Qty.	Description
1	Frame Assembly (A)
2	Support (B)
1	Display (C)
1	Display Bracket (D)
1	Bracket Receiver (E)

Wiring Kit

Qty.	Description
1	5 /16 in. Carriage Bolt
1	5/16" Flange Nut
1	P Clamp
1	Power Harness
1	Display Cable
2	M5 x 8 mm Button Head Screw
2	M5 Washer
5	Push in Cable Clamps
10	Wire Ties

Hardware Bag

Qty.	Description
2	1/2" x 3" Clevis Pin
4	1/2" Washer
4	Bowtie Clip
2	Plastic Spacer
2	1/2" x 1" Clevis Pin

Assembly

1. Insert Plastic Spacer (A) into large holes in rear of utility vehicle frame (B). Attach Frame Assembly (C) to these holes using 1/2" x 3" Clevis Pin (D), 1/2" Washer (E) on outside of utility vehicle frame, another 1/2" Washer (F) on inside of Frame Assembly and fasten with a bowtie clip.

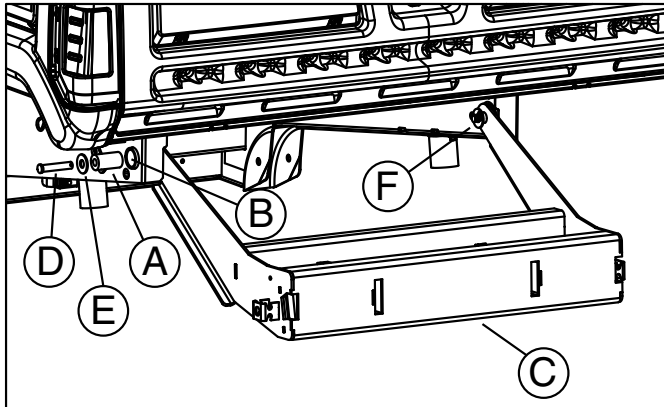

2. With the side pins (G) locked out (pull and turn), slide Supports (H) through the slots in the Frame Assembly at location (J) with the bent end at the top facing towards the outside. Connect hole (K) in the arms to the holes on the utility vehicle frame as shown using two 1/2" x 1" clevis pins and bowtie clips.

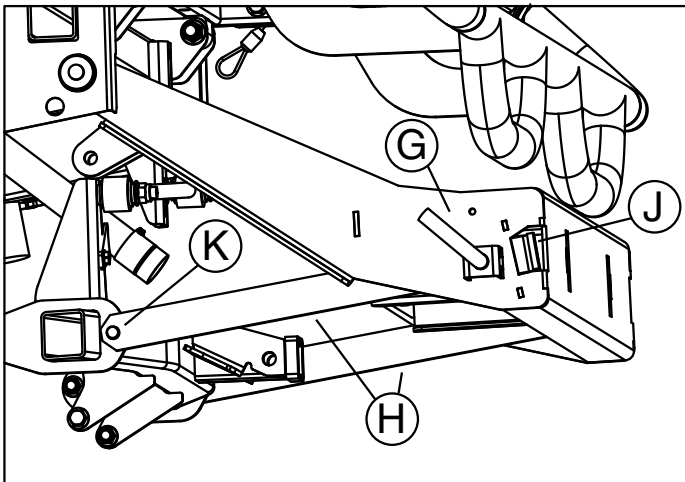

3. Release side pins (G) and lift frame until it clicks into place. Be sure the frame is locked in position before mounting attachment.
4. Slide receiver arms (L) into the slots (M) until it clicks to lock into place. Be sure the hitch latches securely. Adding grease to the slots makes installation easier (It is recommended that two people lift the spreader into place).

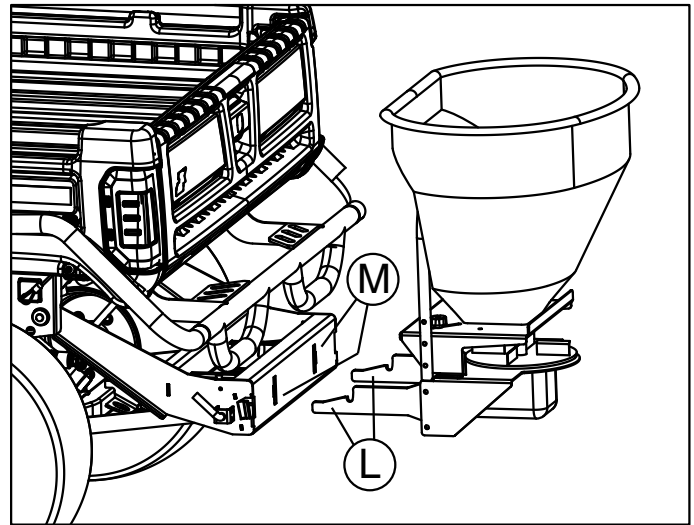

Install Display and Wiring

1. Drill 3/4" hole in the back wall of the glove box on the left side.
2. Under passenger's seat, pull the plastic pin (A) then remove the panel (B) to access the battery compartment.

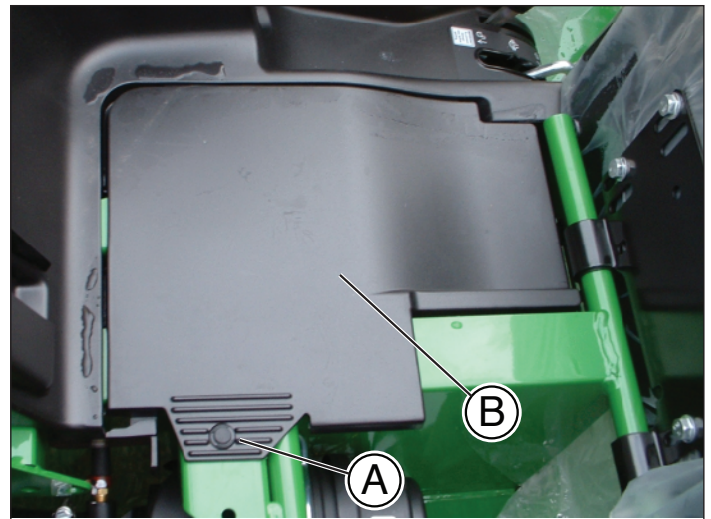

3. Route the end of the power harness with the circular connector from the battery compartment forward to behind the glovebox through the channel on the underside of the vehicle.

4. Install grommet over circular connector on the power harness (C) and feed harness through the hole in the glove box seating the grommet in the hole. Secure harness with a wire tie near the glovebox.

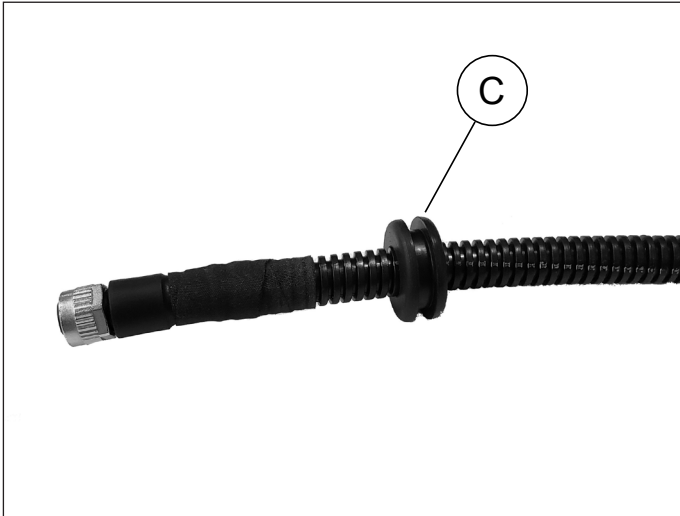

5. Connect the 2 pin connector on the power harness to the accessory port (D) located behind the driver side headlight. And secure to the vehicle harness with a wire tie.

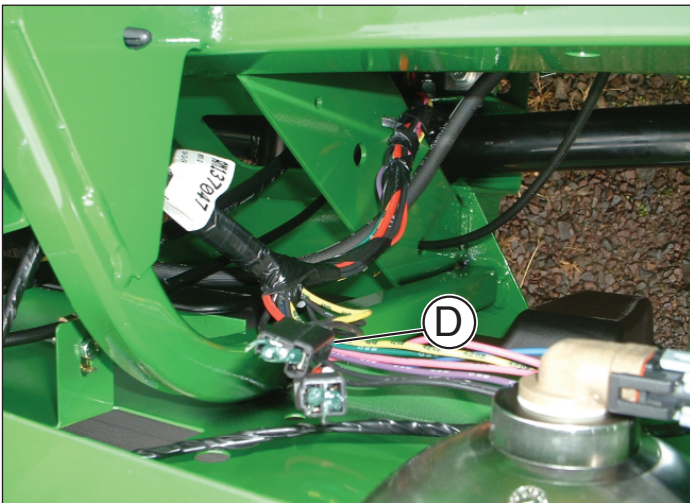

6. Raise the cargo bed and route the other end of the power harness from the battery compartment into the engine compartment on the inside of the right-side frame rail and lightly secure to the vehicle harness with a wire tie.

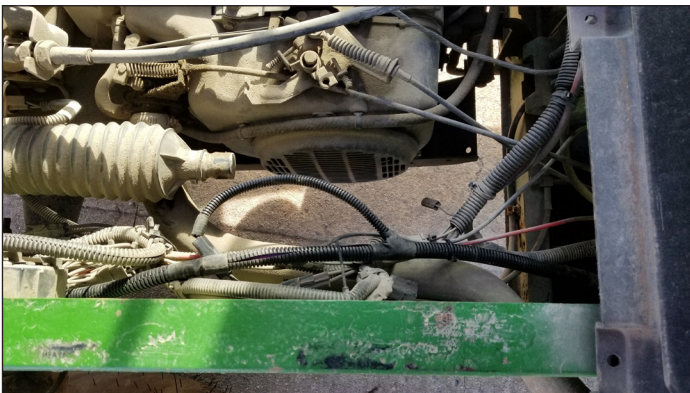

7. Connect the 2 pin connector (E) on the power harness to the rear attachment port connector (F) on the inside of the right frame rail.

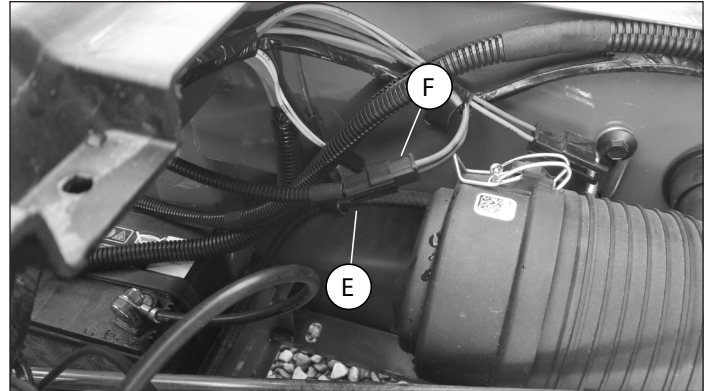

8. Route the rest of the power harness to the rear of the vehicle and attach to the underside of square cross member (G) at the rear of the cargo bed, allow the 2 connectors on the power harness to extend 4 to 6 inches from the end of the cross member.



9. Pull slack from both ends of the harness into the battery compartment and secure with a wire tie. Tighten wire tie on inside of frame rail.
10. Attach display receiver to p-clamp using a 5/16 in. x 3/4 in. carriage bolt (H) and a 5/16 in. flange nut (J).

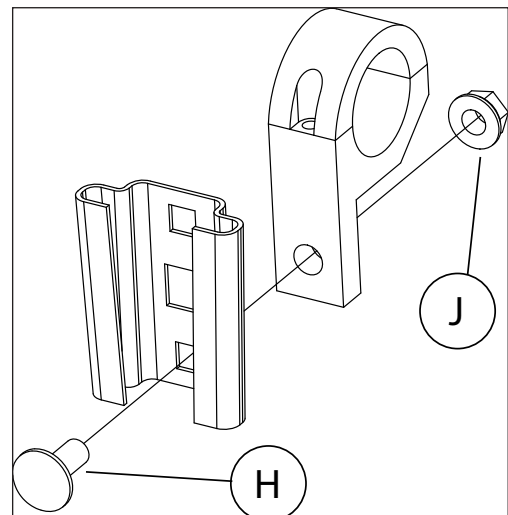

11. Attach the p-clamp to the left side of grab bar in the glove box. Do not fully tighten.

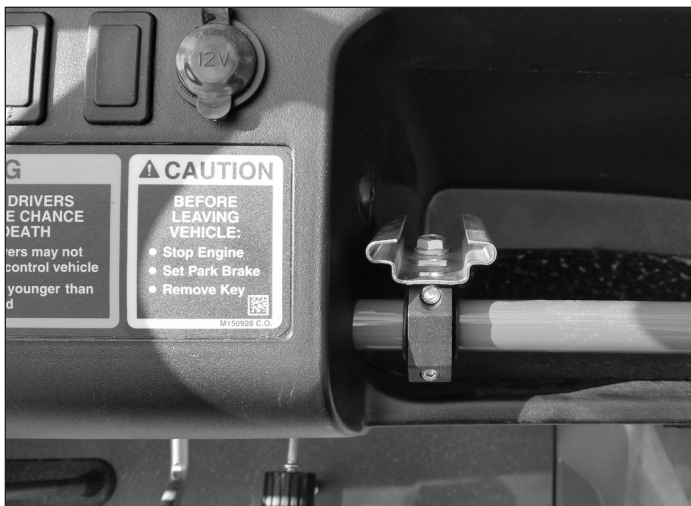

12. Attach the display harness (K) to the connector on the rear of the display (L).

NOTE: Hand tighten the connector coupling nut to 0.5-1.0 ft-lb. Be careful not to cross thread the nut on the plastic threads. Do not twist the overmolded portion of the connector, only twist the metal coupling nut or damage may occur to the Display connector pins.

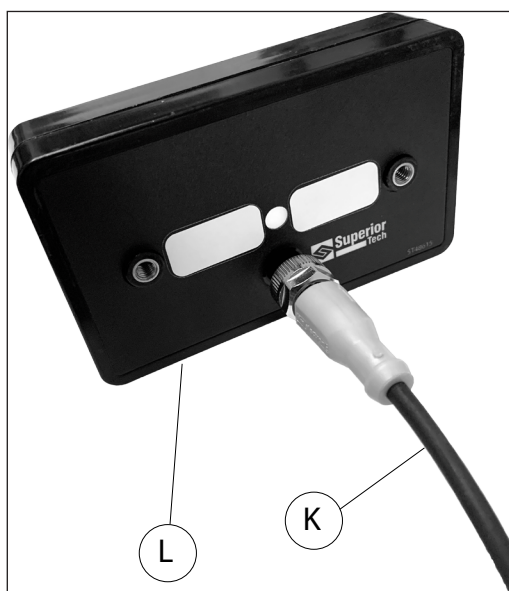

13. Install the Display (M) to the Mounting Bracket (N) using two M5 x 8 pan head screw (P) and two M5 washers (Q).

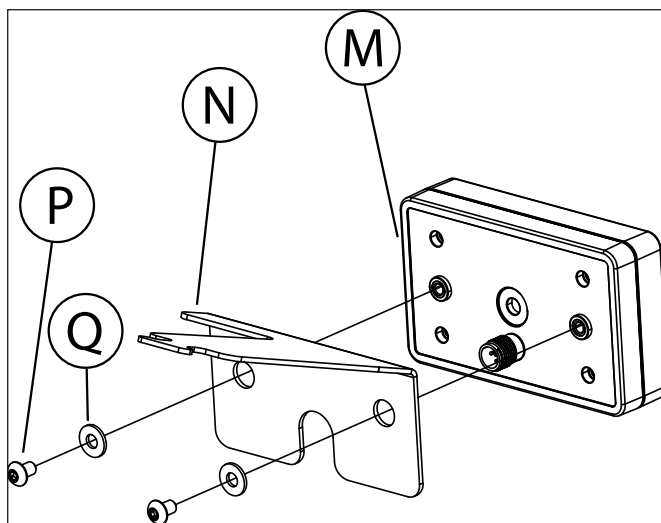

NOTE: Tighten the screws to 4-5 ft-lb. Do not over tighten or damage may occur to the threaded inserts and plastic housing.

14. Mount the Display by sliding the mounting bracket into the receiver and pressing down firmly. Attach the display harness (R) to the power harness (S).

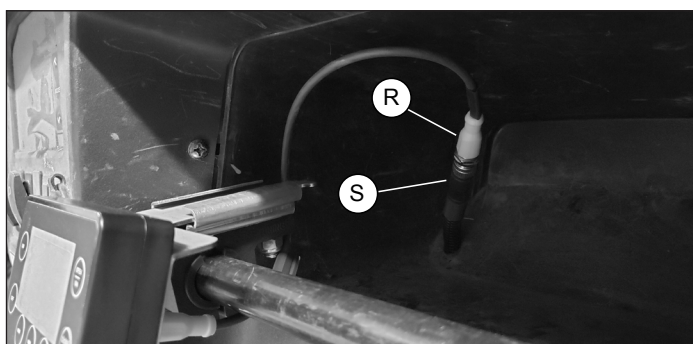

15. Adjust angle of display as best suited for operation and tighten p-clamp to grab bar.

Operation

Raising the utility vehicle bed

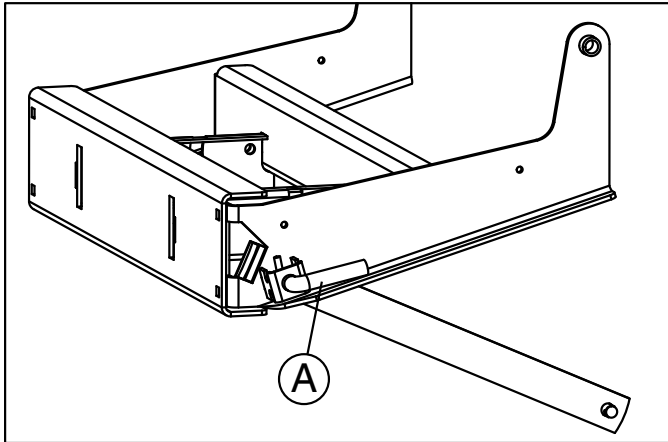

If you wish to raise the bed without removing the attachment mounting frame, it can be folded down by pulling the Pins (A) and turning to lock them out. (Lift up on the frame when pulling the second pin and lower gently to the ground). To put the attachment mounting frame back into position, release the pins and lift the frame until it clicks into position.



Be sure the attachment mounting frame is locked in the up position when operating the vehicle. Driving with the frame folded down may damage the frame or vehicle.

Release attachment

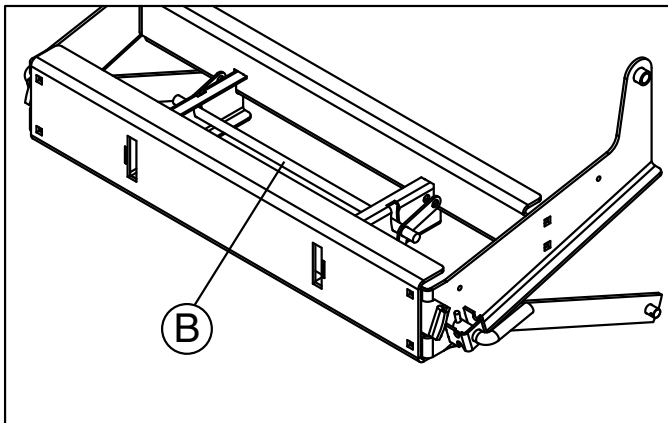

To release an attachment, lift rod (B) and slide the attachment forward slightly. This will unlock it, enabling it to be pulled out.

Remove Display

1. Disconnect display harness (A) from power harness (B).

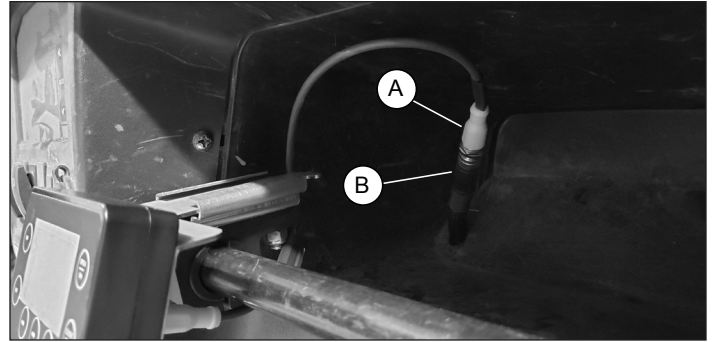

2. Remove display by sliding bracket out of the receiver.
3. Store in a dry location.